

# MANITOU

## MSI 50H

- Maximum Lift Capacity: 10,000 lb.
- Mast Lift Heights to 20 ft. 5 in.
- Perkins 84 HP Engine
- Hydrostatic Transmission
- Enclosed Cab



Shown with optional tires and carriage

 **MANITOU**

# MSI 50H



## Lift Capacity:

Maximum (24 in. load center) . . .10,000 lb.



## Lift Height:

Standard lift height . . . . .to 20 ft. 5 in.



## Tires:

Drive . . . . .15 x 19.5

Steer . . . . .225/75R15 XZM



## Forks:

Length . . . . .48"

Thickness/Width . . . . .2.25" x 6"



## Brakes:

Service . . . . .Hydraulic

Parking brake . . . . .Mechanical



## Engine:

Model . . . . .Perkins 1104C-44

Type . . . . .Diesel

Displacement . . . . .4 cyl. - 243 cu. in.

Power . . . . .84 HP/61.5 KW

Rated Speed . . . . .2200 RPM



## Transmission:

Type . . . . .Hydrostatic

Reversing shift . . . . .Electromagnetic

Maximum travel speed . . . . .15 mph

Number of gears - forward/reverse . .1/1



## Hydraulics:

Pump . . . . .Gear type



## Controls:

Single control proportional levers



## Capacities:

Cooling system . . . . .4 gal.

Engine oil . . . . .2.75 gal.

Hydraulic oil . . . . .41 gal.

Fuel tank . . . . .21 gal.



## Specifications:

Weight . . . . .18,750 lb.

Overall width . . . . .68 in.

Overall height to overhead guard . .96 in.

Turning radius (outside wheels) . .116 in.

Overall length (without forks) . .133 in.

Ground clearance . . . . .8.5 in.

## Mast Selections & Capacities

(Based on 24 in. Load Center)

MFH	Capacity		MFH	Capacity	
	10,000 lb.		6,000 lb.		245"
	127"	163"	10,000 lb.	191"	
	Model 805348-05	Model 805348-06		Model 805358-05	Model 805358-06
*OHL	95"	113"	OHL	95"	113"
*MFH	127"	163"	MFH	191"	245"
*FFH	8"	8"	FFH	66"	84"

2-Stage Mast  
(with no attachments)

3-Stage Full Free Lift Mast  
(with no attachments)

\*OHL = Overall Height Lowered, MFH = Maximum Fork Height, FFH = Free Fork Height

## STANDARD EQUIPMENT:

- Hydrostatic Transmission
- Power Assisted Steering
- Electric Forward /Reverse Shift
- 10° Forward /12° Back Tilt
- Electro-Hydraulic Parking Brake
- Heavy Duty Steer Axle with Integral Cylinder
- Differential Lock
- Enclosed Cab with Tinted Windows
- Adjustable Seat with Hydraulic Shock Absorber
- Electrically Hoisted Cab for Easy Maintenance Access
- Automatic Acceleration System for Lifting
- Backup Alarm
- Front and Rear Worklights

## OPTIONAL EQUIPMENT:

- 2-Stage Mast
- 3-Stage Mast
- Sideshift

## DIMENSIONS:

- A . . . . .48
- B . . . . .82
- C . . . . .27.6
- D . . . . .133
- E . . . . .180
- F . . . . .45.5
- G . . . . .8.5
- G<sub>1</sub> . . . . .5
- O . . . . .6
- P<sub>1</sub> . . . . .5
- R . . . . .116
- U . . . . .96
- W . . . . .68
- Y . . . . .12°
- Z . . . . .10°

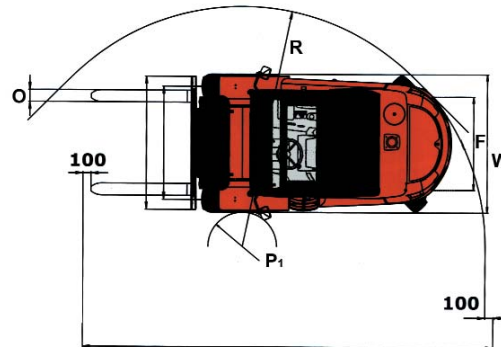
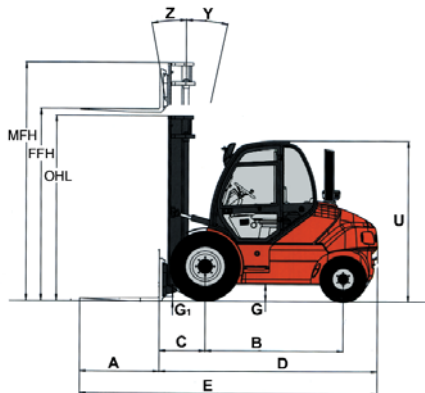

This publication in no way constitutes an offer and the company reserves the right to alter specification without prior notice. The MANITOU models presented in this brochure can be supplied complete with optional equipment attachments.

9/15/05 Printed in U.S.A.

MANITOU NORTH AMERICA, INC.  
P.O. Box 21386  
Waco, TX 76702-1386  
Tel: 800-433-3304 Fax: 254-799-4433  
www.manitou-na.com

