

MANITOU

MSI 30 Series

- Lift Capacity: 6,000 lb.
- Lift Heights to 15 ft. 5 in.
- Perkins Diesel or Toyota LPG Engines
- Hydrostatic Transmission



 **MANITOU**

MSI 30 Series

MSI 30D MSI 30LPG



Lift Capacity

Maximum (24 in. load center) 6,000 lb.



Lift Height:

Standard lift height. to 15 ft. 5 in.



Tires:

Drive 14 x 17.5

Steer 7.00 x 12



Forks:

Length 48"

Thickness/Width 1.75" x 5"



Brakes:

Service Hydraulic

Parking brake Electro-Hydraulic



Engine:

Mode Perkins 404C-22 Toyota 4Y

Type Diesel Propane

Displacement 136.5 cu. in. 165 cu. in.

Power 54 HP 53 HP

Rated Speed 2400 rpm/39kw 2200 rpm/39kw



Transmission:

Type Hydrostatic

Reversing shift Electromagnetic

Maximum travel speed 13 mph



Hydraulics:

Pump with flow divider Gear type



Controls:

Single proportional control joysticks



Capacities:

Cooling system 3 gal.

Engine oil 5 qt.

Hydraulic oil 25 gal.

Fuel tank 19.4 gal.



Specifications:

Weight 8,460 lb 8,260 lb.

Overall width 59 in.

Overall height to overhead guard 83 in.

Turning radius (outside wheels). 96 in.

Overall length 117 in.

Ground clearance (rear axle) 9 in.

Draw bar pull 5,512 lb.

Mast Selections & Capacities

(Based on 24 in. Load Center)

MFH	Capacity	MFH	Capacity
6,000 lb.	130"	6,000 lb.	185"
	Model 800509	158"	Model 800493
			Model 800494
*OHL	90.7"	OHL	84.6"
			94.6"
*MFH	130"	MFH	158"
			185"
*FFH	0"	FFH	55"
			64"

2-Stage Mast
(with no attachments)

3-Stage Full Free Lift Mast
(with no attachments)

*OHL = Overall Height Lowered, MFH = Maximum Fork Height, FFH = Free Fork Height

DIMENSIONS:

	30D	30LPG
A	48	48
B	71	71
C	25	25
D	117	117
E	165	165
F	40	40
F1	48	48
G	10.5	10.8
G*	9.5	9.5
G1	9.5	9.5
G1*	9.5	9.5
G2	8.5	8.5
G2*	9	9
G3	10.5	10.5
I	21	21.6
J	40	40
K	49.5	49.5
L	1.75	1.75
N	57	57
O	5	5
P1	49.5°	49.5°
P2	40.5°	40.5°
P3	40°	40°
R	96	96
S	99.5	99.5
T	178	178
U	83	83
V	102	102
V1	4	4
W	59	59
Y	12°	12°
Z	10°	10°

G* = Loaded

STANDARD EQUIPMENT:

- Hydrostatic Transmission
- Power Assisted Steering
- Electric Forward/Reverse Shift
- 10° Forward/12° Back Tilt
- Heavy Duty Steer Axle with Integral Cylinder
- Electro-Hydraulic Parking Brake
- Noise Reduction
- Electrically Hoisted Cab for Easy Maintenance Access
- Adjustable Seat with Hydraulic Shock Absorber
- Automatic Acceleration System for Lifting
- Single Joystick Combines Up/Down/Tilt

OPTIONAL EQUIPMENT:

- 90.7/0/130 2-Stage Mast
- 84.6/55/158 3-Stage Mast
- 94.6/64/185 3-Stage Mast
- Fully Enclosed Cab
- Sideshift
- Worklights

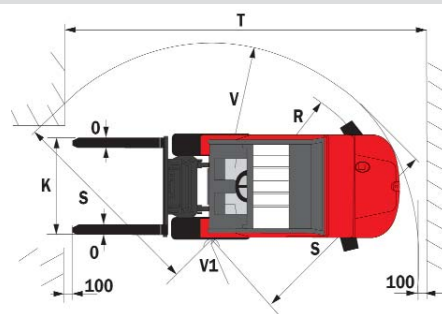
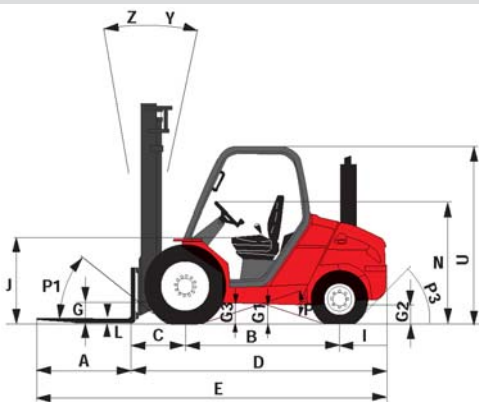

This publication in no way constitutes an offer and the company reserves the right to alter specification without prior notice. The MANITOU models presented in this brochure can be supplied complete with optional equipment attachments.

9/15/05 Printed in U.S.A.

MANITOU NORTH AMERICA, INC.
P.O. Box 21386
Waco, TX 76702-1386
Tel: 800-433-3304 Fax: 254-799-4433
www.manitou-na.com

