



3,000-4,000 lb Capacity 3-Wheel Electric Forklift Trucks





Quality And Support For The Long Haul

Our services are as innovative as our forklifts. One example is our exclusive Mastersource® parts program, designed to be your single source for quality replacement parts—no matter what forklift brand you own. Another is our Master Protection® program which offers extended powertrain warranties for your Mitsubishi forklifts.

Your Mitsubishi forklift truck dealer offers an extensive line of products and services including Master Maintenance® programs, which tailor service and maintenance to your specific applications. Your Mitsubishi forklift truck dealer can provide options and additional visual and audible warning devices aimed at your specific applications and requirements. Operator training programs are also available to help reduce the potential for product damage and personal injury.

*Truck shown contains some optional equipment. Contact an authorized Mitsubishi forklift truck dealership for the most up to date information about equipment availability and forklift truck specifications.



Exceptional Maneuverability

3,000-4,000 lb Capacity 3-Wheel Electric Forklift Trucks

Value By Design

Mitsubishi FB16NT-FB20NT forklift trucks are **Ready, Reliable, and Right On The Money.** With their 100 percent Alternating Current (AC) design, these trucks will exceed your expectations for Quality, Reliability, and Value in warehouse, shipping, and other applications that require fast travel speed and exceptional maneuverability.

With service intervals up to 500 hours, a flexible rental program and versatile financing options, these dynamic, versatile trucks can help improve the profitability of your operations by reducing the overall costs of material handling.

MODEL NUMBER	BASE CAPACITY AT 24 IN. LOAD CENTER (lbs.)	MINIMUM AISLE WIDTH / ADD LOAD LENGTH AND CLEARANCE (in.)	BATTERY COMPARTMENT L x W x H (in.)
FB16NT	3,000	75.0	20.9 x 40.0 x 24.8
FB18NT	3,500	75.0	24.9 x 40.0 x 24.8
FB20NT	4,000	75.0	24.9 x 40.0 x 24.8

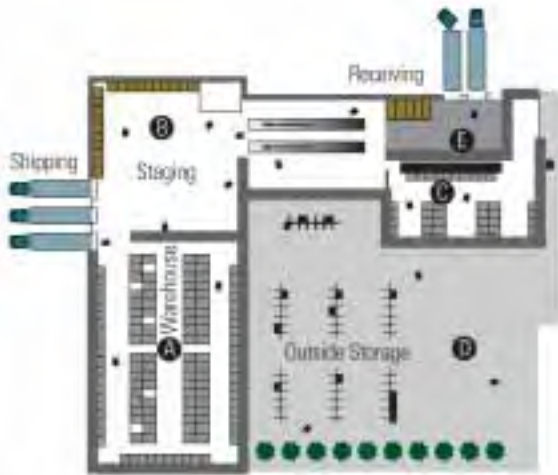

Customized Performance

From the warehouse to the loading dock, these versatile trucks can be programmed to meet the specific demands of your application. Travel speed, lifting speed, acceleration rate, regenerative braking, and auto regenerative braking can be adjusted through the onboard Application Control System to optimize efficiency across shifts and applications.

Application A: Warehouse / General Use

- Moderate travel speed
- Moderate lift and tilt requirements

Application B: High Performance Use

- High travel speed
- High lift and medium tilt speeds

Application C: High Traffic Areas / Economy Use

- Low travel speed
- Low lift and medium tilt speeds

Application D: Long Travel Applications

- High travel speeds
- Moderate lift and tilt speeds

Application E: Dock Work / Short Shuttle Applications

- Moderate travel speeds
- High lift speeds and moderate tilt speeds

More Functionality For Greater Value

These 3,000 to 4,000 lb capacity electric Mitsubishi forklift trucks are ready for action, with AC technology and an advanced control system designed for fast acceleration, high top speed, quick deceleration, fast lift/lower speeds, and significant reductions in overall energy consumption.



Getting You There...Faster

The FB16NT features travel speeds up to 10.6 mph, loaded or empty, providing exceptional efficiency for applications requiring extended travel.



APPROXIMATE AISLE WIDTH (in.)	MINIMUM WORKING AISLE (in.)	CAPACITY RANGE (lbs.)
Stand-Up End Control	123.0 - 128.5	3,000 - 5,000
FB16NT - FB20NT Generation	128.5 - 134.0	3,000 - 4,000
4-Wheel Sit-Down Electric	139.0 - 150.5+	3,000 - 6,500+

* Based on 48 in. load length and minimum operating clearance of 6 in.

Tighter Turns For Faster Throughput

These 3-wheel forklift trucks combine maneuverability and quick travel speeds. With the ability to perform in a variety of applications including on uneven floors, these trucks are ideal for general warehouse use, or loading and unloading trailers.



Designed To Perform

Narrow mast channels and well positioned cylinders, chain, and hose routings provide good forward visibility in comparison with competitive 3-wheel forklifts. This family of forklifts also offers powerful lift/lowering, delivering lift speeds up to 98 feet per minute (fpm) loaded or 118 fpm empty, and lowering speeds up to 102 fpm loaded or 98 fpm empty.



Protecting Loads And Operators Against Misuse

The innovative Mitsubishi Integrated Presence System (IPS) helps protect your operator and your materials. When your operator leaves the normal seated operating position, the following occurs:

- The drive function is temporarily disengaged.
- Power temporarily disconnects from the hydraulic lift and tilt functions.
- In addition, if the operator has not applied the parking brake, an alarm will sound.

When your operator returns to the normal seated operating position, a buzzer will sound to remind him to fasten his seat belt.



Monitoring Performance

A Liquid Crystal Display (LCD) and Light Emitting Diodes (LED) are standard with these trucks, making it easy for your operators to monitor travel speed and battery charge. A service due indicator and fault history folder that stores up to 32 fault codes enables you to manage scheduling and routine maintenance more efficiently.



The Benefits Of AC Design

Reliable AC motors ensure faster acceleration, higher top speed, quicker deceleration, and better lift and lower speeds in comparison with DC models. In addition, AC motors are brushless, reducing maintenance and long-term cost of ownership.

More Performance With Increased Energy Efficiency

The Mitsubishi PM-1000 control system uses advanced MOSFET and heat-dissipation technology to help ensure reliable performance while saving energy. For thermal management, the transistors are mounted on Insulated Metal Substrate (IMS), improving heat dissipation and eliminating the need for cooling fans. This improves the durability of the control system with a reduced risk of component failure. Unlike conventional “boxed” designs, The PM-1000 control system is modular in design. Separating the power unit and logic from the power inverter and digital signal processing card enables service technicians to replace components individually for significant savings in time and money.

PM-1000

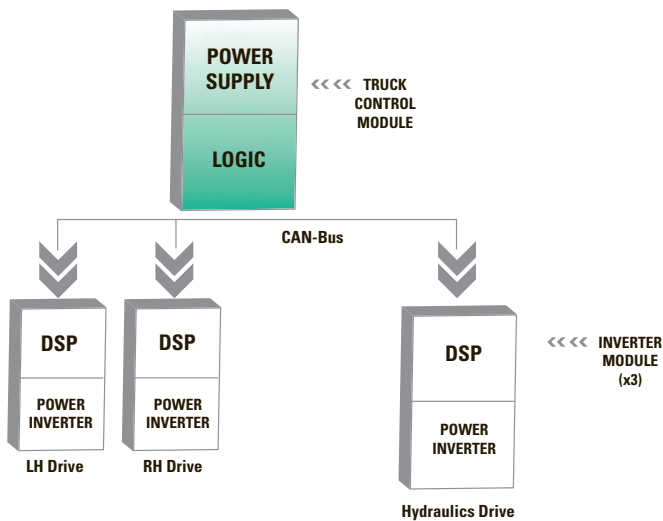

Battery Information

BATTERY COMPARTMENT SIZE		FB16NT		FB18NT		FB20NT	
Length	in mm	20.9	530	24.9	634	24.9	634
Width	in mm	40.0	1016	40.0	1016	40.0	1016
Height	in mm	24.8	630	24.8	630	24.8	630
BATTERY WEIGHT							
Minimum	lb kg	1910	870	2200	1000	2200	1000
Maximum	lb kg	2400	1090	2700	1227	2700	1227
BATTERY SPECIFICATIONS							
Connector Position		B		B		B	
Lead Length	in mm	20.0	508	20.0	508	20.0	508

Specifications

CHARACTERISTICS				FB16NT		
1	Capacity	at rated load center	lb kg	3000	1600	
2		at load center – distance	in mm	24.0	500	
3	Power	diesel, gasoline, LP gas, electric		electric		
4	Tire type	cushion, pneumatic		cushion		
5	Wheels (x = driven)	number front / rear		2x / 2		
DIMENSIONS						
10	Lift	maximum fork height with rated load	in mm	188	4790	
11	Lift with standard two-stage mast	maximum fork height	in mm	130	3300	
12		free fork height	in mm	4.5	115	
13	Forks	thickness x length x width	in mm	1.4x42x3.9	35x1070x100	
	Fork spacing	out-to-out minimum / maximum	in mm	9.4/36.0	240/918	
14	Tilt	forward / backward		6/7		
15	Overall dimensions	length to fork face	in mm	74.5	1895	
16		width	standard	in mm	42.0	1070
			w/ wide stance drive wheels	in mm	n / a	
17		height	with lowered mast	in mm	83.0	2105
18			seat height to SIP	in mm	41.3	1048
19			to top of overhead guard	in mm	80.5	2040
20	with extended mast		in mm	179.0	4550	
21	Minimum outside turning radius		in mm	59.5	1515	
22	Load moment constant		in mm	14.8	376	
23	Minimum aisle - 90 deg. stack – zero clearance w/o load		in mm	74.5	1893	
PERFORMANCE						
24	Speeds	travel loaded / empty	36V	mph km/h	9.4/10.6	15.1/17.0
			48V	mph km/h	10.6/10.6	17.0/17.0
lift speed loaded / empty		36V	fpm m/s	79/110	0.40.56	
		48V	fpm m/s	98/118	0.50.60	
26	Gradeability	lowering speed loaded / empty	36V	fpm m/s	102/98.0	0.52/0.50
			48V	fpm m/s	102/98.0	0.52/0.50
loaded at 1 mph (1.6 kph)		36V	%	13		
		48V	%	27		
28	maximum empty	36V	%	30		
		48V	%	35		
WEIGHT						
29		Empty	w/ minimum weight battery	lb kg	6800	3090
30	Axle load	with rated load	front	lb kg	9200	4175
			rear	lb kg	1140	515
		without load	front	lb kg	3300	1500
			rear	lb kg	3500	1590
CHASSIS						
31	Tire size	front, standard cushion tires	in mm	18x7x12 1/8	457x178x308	
		rear cushion tires	in mm	15X5X11 1/4	381x127x286	
32	Wheelbase		in mm	51.5	1305	
33	Tread width	front, standard cushion tires	in mm	35.0	894	
34		rear cushion tires	in mm	6.7	170	
35	Ground clearance	at lowest point at mast	in mm	2.9	75.0	
36		at center of wheelbase	in mm	3.9	100	
37	Brakes	service	type	foot-operated, hydraulic		
38		parking	type	hand-operated, mechanical		
POWERTRAIN						
39	Battery	type		lead-acid		
40		maximum capacity	Ah kWh	950	34.2	
41		at 6 hr. discharge rate	Ah kWh	770	37.0	
42		weight, minimum	lb kg	1910	865	
43	Motors	traction output (60 min. rating) x 2	HP kW	6.7	5.0	
		lift output (15% rating)	HP kW	18.7	14.0	
45	Controls	drive	type	AC Transistor		
46		hydraulic		AC Transistor		
47	Relief pressure	for attachments at auxiliary	psi bar	2250	155	
48	Noise level	mean value at operator's ear	dB(A)	69.2		

FB18NT		FB20NT	
3500	1800	4000	2000
24.0	500	24.0	500
electric		electric	
cushion		cushion	
2x / 2		2x / 2	
188	4790	171	4350
130	3300	130	3300
4.5	115	4.7	120
1.4x42x3.9	35x1070x100	1.6x42x3.9	40x1070x100
9.4/36.0	240/1918	9.4/36.0	240/1893
6/7		6/7	
78.5	1995	80.2	2035
42.0	1070	42.0	1070
n / a		n / a	
83.0	2105	83.0	2105
41.3	1048	41.3	1048
80.5	2040	80.5	2040
179.0	4550	179.0	4550
64.0	1620	65.0	1645
14.8	376	15.4	392
78.5	1996	80.0	2037
8.9/10.6	14.4/170	8.5/10.6	13.7/170
10.6/10.6	170/170	10.6/10.6	170/170
69.0/110	0.35/0.56	67/110	0.34/0.56
87.0/118	0.44/0.60	79/118	0.4/0.60
102/98.0	0.52/0.50	102/98.0	0.52/0.50
102/98.0	0.52/0.50	102/98.0	0.52/0.50
12		11	
25		23	
28		26	
35		35	
7250	3290	7750	3520
9900	4500	10,700	4870
1300	590	1430	650
3500	1590	3550	1610
3750	1700	4200	1910
18x7x12 1/8	457x178x308	18x7x12 1/8	457x178x308
15X5X11 1/4	381x127x286	15X5X11 1/4	381x127x286
55.5	1410	55.5	1410
35.0	894	35.0	894
6.7	170	6.7	170
2.9	75.0	2.9	75.0
3.9	100	3.9	100
foot-operated, hydraulic		foot-operated, hydraulic	
hand-operated, mechanical		hand-operated, mechanical	
lead-acid		lead-acid	
950	34.2	950	34.2
770	370	770	370
2200	1000	2200	1000
6.7	5.0	6.7	5.0
18.7	14.0	18.7	14.0
AC Transistor		AC Transistor	
AC Transistor		AC Transistor	
2250	155	2250	155
69.2		68.5	

Call-out numbers shown in diagram correspond to the first column of the specifications chart.

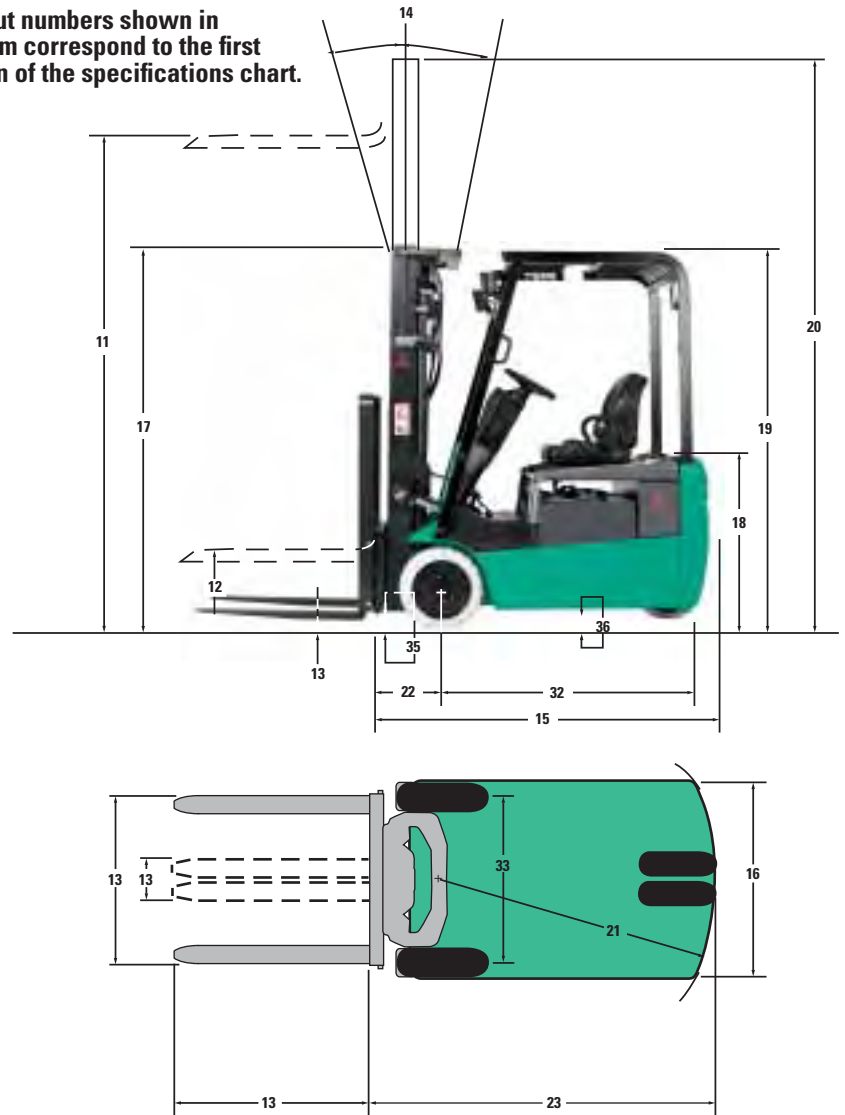

SAFETY STANDARDS

These trucks meet American Society of Mechanical Engineers (ASME) B56.1, part III Safety Standards for powered industrial trucks.

UL-Classified by Underwriters Laboratories, Inc., as to fire and electric shock hazard only. Availability: Type E standard. Type ES, EE optional.

Users should be aware of, and adhere to, applicable codes and regulations regarding operator training, use, operation and maintenance of powered industrial trucks, including:

- ASME B56.1, part II.
- NFPA 505, fire safety standard for powered industrial trucks – type designations, areas of use, maintenance and operation.
- Occupational Safety and Health Administration (OSHA) regulations that may apply.

Contact your Mitsubishi forklift truck dealer for further information including operator training programs and auxiliary visual and audible warning systems, fire extinguishers, etc., as available for specific user applications and requirements.

Specifications, equipment, technical data, photos and illustrations based on information at time of printing and subject to change without notice. Some products may be shown with optional equipment.

NOTE: These specifications assume the use of drive axles, tires and tilt angles specified. Any modification to specifications, or any other combination of specifications made after the shipment of the truck, requires prior written approval from Mitsubishi Caterpillar Forklift America Inc. ("MCFA"). (See ASME B56.1 Part II 4.2.) Also be advised that overall operating visibility may be affected by the mast configuration and mast options of your truck. Therefore, you may need to add auxiliary devices or modify your operating practices. Consult your dealer for further information.

Ready. Reliable. Right On The Money.

Manufactured with superior quality and exceptional value, Mitsubishi forklift trucks are equipped with extensive dealer and field support including a convenient equipment rental program, dealership locations throughout North America and South America, flexible financing options and parts distribution centers conveniently located across the U.S.A.



**For more information, call 1-888-MIT-LIFT
or your local Mitsubishi forklift truck dealer.**





**3,000-4,000 lb Capacity
3-Wheel Electric
Forklift Trucks**

Specifications, equipment, technical data, photos, and illustrations based on information at time of printing and subject to change without notice. Some products may be shown with optional equipment. MASTERSOURCE and MASTER MAINTENANCE are registered trademarks of MCFA. Copyright © 2006 by MCFA. All Rights Reserved. Printed in U.S.A.

MECM0010-02

03/06



1-888-MIT-LIFT
www.mit-lift.com

MCFA • 2121 W. Sam Houston Parkway North
Houston, TX 77043